

Standard Full Nut

Thread Type: UNF - Fine

Thread Direction: Right Hand

Material: Stainless Steel

Class Grade: A2-70 G304

Corrosion Protection Level: Excellent

Standard: ANSI B18.2.2

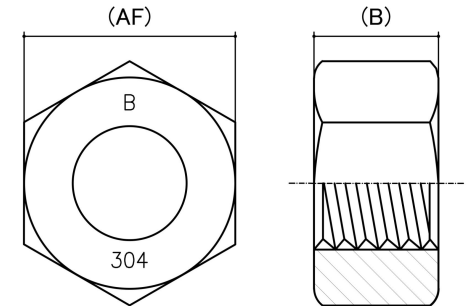

*CAD drawings shown for graphic representation only.**

Size	Thread Pitch (TPI)	Thread Type	Overall Nut Height (B) (mm)		Across Flats (AF) (mm)		Spanner Size (AF) (inches)	sku (qfind)
			Min	Max	Min	Max		
1/4"	28	Fine	5.39	5.75	10.88	11.16	7/16	41SF14
5/16"	24	Fine	6.56	6.94	12.43	12.76	1/2	41SF516
3/8"	24	Fine	8.13	8.56	14.00	14.28	9/16	41SF38
7/16"	20	Fine	9.28	9.78	17.15	17.48	11/16	41SF716
1/2"	20	Fine	10.85	11.38	18.70	19.05	3/4	41SF12
5/8"	18	Fine	13.59	14.20	23.42	23.83	15/16	41SF58
3/4"	16	Fine	15.68	16.90	27.64	28.58	1-1/8	41SF34
7/8"	14	Fine	18.39	19.72	32.24	33.33	1-5/16	41SF78
1"	12	Fine	21.11	22.53	36.83	38.16	1-1/2	41SF1

Disclaimer:

Dimensional data and technical information was obtained from publically available sources and not acquired through standard agencies. It has been completed and compiled for reference purposes only; where discrepancies are found they are subject to change without notice. Bolt & Nut Australia makes no warranties or representations regarding the accuracy and validity of the compiled information and data. Contact the relevant standard authorities for accurate and detailed information.

* CAD drawings may not reflect diameter, thread length or overall length.

© Bolt & Nut Australia Pty Ltd. All rights reserved.

Version: 18 Mar 2024